

Manual

Safety Light Curtains

WITH IN BUILT CONTROLLER



**Over 14,000
installations**



Orbital Systems (Bombay) Pvt. Ltd.

READY RECKONER - I

Parameter	Code	Specifications
Supply Voltage (V)	1	110 VAC \pm 15%, 50Hz
	2	230 VAC \pm 15%, 50Hz
	3	24 VDC \pm 15%
Number of Channels (C)	A	04 Channels
	B	08 Channels
	C	12 Channels
	D	16 Channels
	E	24 Channels
	F	32 Channels
	G	48 Channels
	H	36 Channels
	I	20 Channels
Range (R)	1	5000 mm
	2	Special
Pitch (P)	A	50 mm
	B	3 mm
	C	18.3 mm
	D	36.6 mm
	E	30 mm
	F	30 & 50 mm
	G	15 mm
	H	57 mm
Type of Output (O)	1	2 x N/O Contact
	2	2 x N/C Contact
	3	1 C/O Relay Contact
	4	PNP NO
Model	S	Standard
	M	Inbuilt control box
	I	Intelligent channel bypass
	E	Slim-Line photo screen
Screen Height available		90, 105, 150, 210, 210, 225, 345, 350, 450, 465, 570, 690, 750, 930, 1150, 1550, 1800, 2000.

FEATURES

- **Micro controller based Embedded technology**
- **SELF TEST** : Built in self test to ensure that the electronic Components and logic circuit are functioning properly. System will go to wait state if the self test detect a malfunction.
- **DUAL ELECTRONIC CIRCUITS** : with separate outputs and Feedback for each output to add the reliability and to ensure failsafe operation.
- **BUILT IN SURGE SUPPRESSOR** : to safeguard against power Supply surges and electrical noise.
- **HOUSING** : extruded Aluminium Sections ensure that the Product can withstand severe mechanical impacts.
- **MOUNTING** : "T"slots allow for easy mounting arrangements.
- **OPTICS** : well designed optics ensure easy alignment.
- **OPTICAL COMMUNICATION**: No interconnecting cables. Immune to noise.
- **CHANNEL BY PASS OPERATION**: Programming of channels into bypass condition.

SAFETY LIGHT CURTAINS

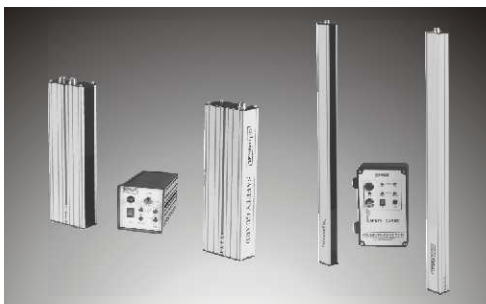

Technical Specifications:

Operating Range	: upto to 7000mm
Detection	: Dia 25mm (For 15mm Pitch)
Capabilities	: Dia 40mm (For 30mm Pitch) Dia 60mm (For 50mm Pitch)
Effective Angle	: $\pm 5^\circ$
Supply Voltage	: 240 VAC -20% +10%, 50 Hz /110 VAC / 24 VDC
Output	: 2 N/O Contacts, 250V. 5A Resistive
Response Time	: Off Response 15 msec
Indicator	: Being Alignment Indicator, 2 Red LED on Transmitter
Temperature	: -10 to 60°C
Humidity	: 30 to 85% RH
Emitting Element	: Infra Red LED
Vibration	: 10 to 55 Hz, 0.75mm Amplitude in X Y& Z Direction
Resistance	: For 2 Hours each 30 msec ² Acceleration (30 G approx.) in X, Y& Z direction for three time each

Ready Reckoner for Safety Light Curtains

Screen Height (mm)	No. of Channel	Pitch	Length	Product Code
90	04	30	180	AA□A□E□S
105	08	15	180	AA□B□G□S
150	04	50	180	AA□A□A□S
210	08	30	275	AA□B□E□S
225	16	15	400	AA□D□G□S
345	24	15	600	AA□E□G□S
350	08	50	400	AA□B□A□S
450	16	30	600	AA□D□E□S
465	32	15	600	AA□F□G□S
570	16	30 & 50	600	AA□D□F□S
690	24	30	800	AA□E□E□S
750	16	50	800	AA□D□A□S
930	32	30	1000	AA□F□E□S
1150	24	50	1500	AA□E□A□S
1410	48	30	1500	AA□G□E□S
1550	32	50	1800	AA□F□A□S

For Safety Light Curtains with intelligent bypass

210	8	30	275	AA□B□E□I
350	8	50	400	AA□B□A□I
450	16	30	600	AA□D□E□I
750	16	50	800	AA□D□F□I
930	32	30	1000	AA□F□E□I
1410	48	30	1500	AA□D□E□I

SAFETY LIGHT CURTAIN WITH IN BUILT CONTROLLER

Technical Specifications:

Operating Range	: 5000 mm upto 15000 mm
Effective Angle	: $\pm 5^\circ$
Supply Voltage	: 24 VDC $\pm 20\%$
Output	: 2 x PNP N/O
Response Time	: 15 m sec
Temperature	: 0 to 60°C
Humidity	: 30 to 85% RH
Emitting Element	: Infra Red LED
Peak Emission Wavelength	: 940 nm
Output Load current	: Max. 100 mA
Vibration Resistance	: 10 to 55 Hz, 0.75mm Amplitude in X Y & Z Direction For 2 Hours each 30 msec ² Acceleration (30 G approx.) in X, Y & Z direction for three time each
Connection	: Transmitter 2 Pin connector & Receiver 4 pin connector
Dimension	: 31 mm (Width) x 41 mm (Breadth) x Total Height



READY RECKONER

Screen Height (mm)	No. Of Channel	Pitch (mm)	Total Height (mm)	Product Code
145	8	18.3	205	AC □ B □ C □ M
220	12	18.3	280	AC □ C □ C □ M
290	16	18.3	350	AC □ D □ C □ M
365	20	18.3	425	AC □ I □ C □ M
440	24	18.3	500	AC □ E □ C □ M
585	32	18.3	645	AC □ F □ C □ M
660	36	18.3	720	AC □ H □ C □ M
880	48	18.3	940	AC □ G □ C □ M
290	8	36.6	350	AC □ B □ D □ M
440	12	36.6	500	AC □ C □ D □ M
585	16	36.6	645	AC □ D □ D □ M
730	20	36.6	790	AC □ I □ D □ M
880	24	36.6	940	AC □ E □ D □ M
1170	32	36.6	1230	AC □ F □ D □ M
1315	36	36.6	1375	AC □ H □ D □ M
1755	48	36.6	1815	AC □ G □ D □ M

ORDERING CODE: (Refer READY RECKONER - I)

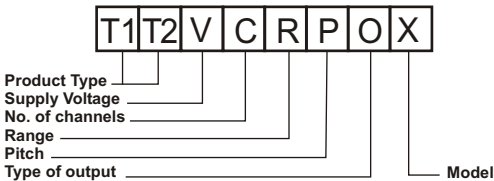

- | | |
|---|---|
| □ → Model:-
M : Inbuilt control box
I : Intelligent Channel Bypass
E : Slim-line Photo Screen
S : Standard | Product type (T1, T2):-
AA = Safety light curtain
AB = Photo screen for part sensing
AC = Inbuilt control box
AD = Slim-Line photo screen |
|---|---|

Safety Relay Unit

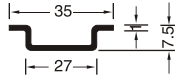

DIN RAIL-DIN EN.50022

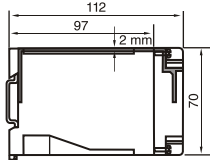
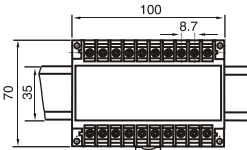

Specifications

Supply voltage		90 - 260 VAC
Current consumption		500 mA
In Put	Applicable input	PNP or contact input
	2 channel	2 channel
	Rated applied voltage	24 V DC
Output	Safety circuit output	NO contact X 2
	Rated voltage	24 V DC
Ambient temperature		0 to 55°C, Storage 0 to 70°C
Ambient humidity		35 to 85% RH , Storage: 35 to 85% RH
Vibration resistance		10 to 55Hz frequency, 0.5mm amplitude (checked in three directions)
Material		Enclosure: Glass fiber-reinforced thermoplastic
Connecting method		Terminal block connection (self-up screw)

Controller Connection Diagram

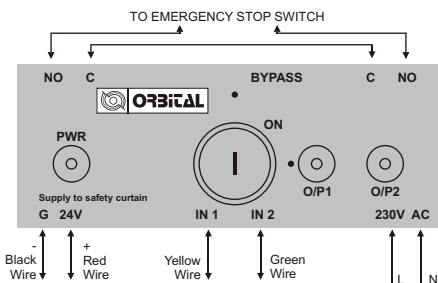

ELEVATOR LIGHT CURTAINS



Features

- Micro controller based Embedded technology
- Pulsed, Modulated & Scanned Logic
- Crisscross Beam Pattern
- Extensive fault diagnosis
- Intelligent bypass of individual channels
- Inbuilt Surge & Spike Protection
- Extremely Rugged

Technical Specifications

Number of beams(Max.)	94
Response time(mS)	69.2
Range of detection	0-3000mm
Active protection height	20-1841mm
Vertical mounting tolerance	+/- 20mm/10°
Horizontal mounting tolerance	+/- 3mm/7°
Light immunity(LUX.)	100000
Operating temperature	-20°c — +65°c
LED indicators	Green: power supply; Red: signal indicators
Housing material	Aluminum alloy, finished black
Housing dimension(L)	2000mm
Housing dimension(W)	38mm
Housing dimension(D)	10mm
Power Consumption	3W
System marking	CE

Installation Dimension

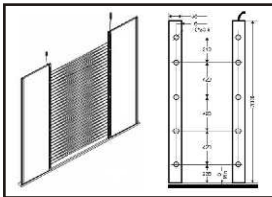

Housing Dimension

Depth	10MM
Width	38MM

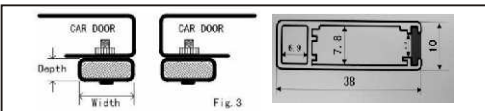

Elevator Door Detector (Elevator Light Curtain) Power Unit

Please make sure that all the wires are connected according to the following diagram

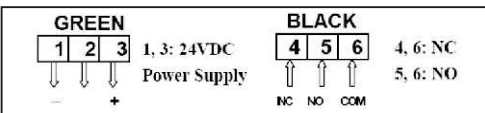

Introduction

The Orbital **AC Series Safety Light Curtain** is a compact infrared multi-beam device designed to increase the protection of operators working with dangerous machines. The AC Series product is ideal for the protection of work stations where space is critical.

Instruction Manual

Orbital AC Series safety light curtain devices described in this manual are designed to protect humans from danger zones normally associated with the moving parts of machinery.

To ensure the full benefits of this protection, the safety light curtains described in this manual must be properly selected, installed, maintained and operated.

Control reliability

“Control Reliability” means that, “the device, system or interface shall be designed, constructed and installed such that a single component failure within the device, interface or system shall not prevent normal stopping action from taking place but shall prevent a successive machine cycle.” (ANSI B11.19-1990, 5.5)

OSHA 29 CFR 1910.217 states that, “the control system shall be constructed so that a failure within the system does not prevent the normal stopping action from being applied to the press when required, but does prevent initiation of a successive stroke until the failure is corrected. The failure shall be detectable by a simple test, or indicated by the control system.”

Orbital uses self-checking technique that combines reliability with safety. The AC Series safety light curtain functions with dual channel redundancy in all critical areas and positive self-check monitoring. This means that a faulty component in the safety light curtain will cause it to fail in a safe mode. Besides, two separate outputs are provided and feedback from each output is checked to add to the reliability of the safety light curtain.

Permanent **self-checking** based on microprocessor technology comply to the requirements of European standards for type 4 electro sensitive protective equipment.

IEC 16496-1 & IEC 16496-2. These AC series safety light curtains are designed and manufactured in such a way that a single breakdown or an accumulation of failures does not lead to the loss of the safety function when a dangerous situation arises. This design complies to the highest safety requirements (Type 4 Electro sensitive Protective equipment).

The safety function is maintained on a permanent basis.

Description

Control and sensing unit

The Orbital AC Series safety light curtain is an infrared multi-beam device designed to protect operators working on dangerous machines. Entering the invisible sensing field causes the light curtain output contacts to open. An emergency stop condition is then sent to the machine control circuitry. Detection of the operator body parts will lead to the immediate stoppage of the moving parts of the machine.

The AC Series device consists of Emitter and Receiver sensing units. Each light curtain unit is made up of a row of emitting circuits and a row of receiving circuits with a beam spacing of 18.3 mm or 36.6 mm and are mounted in extruded aluminum "C" housings with a cross section of 31 mm x 41mm.

The AC Series safety light curtains are ideal for the protection of workstations on machines such as Power Presses, Paper-cutting machines, Robots, S.P.M.s, Molding machines, Area Guarding and other applications.

Specifications

OPERATING CHARACTERISTICS

Resolution (minimum object detection)	30 mm
Response Time	20 ms
Restart time	< 300 ms
Scanning Range	5000 mm standard, more on request
Emission	Modulated infrared light (940nm)

ELECTRICAL CHARACTERISTICS

Supply voltage	22 to 30 Vdc or 110 to 230 Vac
Current consumption	< 200 mA
Output switching capacity	2 PNP NO Output , 200mA
LED Indication	Ready – Yellow Power – Red Wait – Red ON - Green
Electrical connection	Pre-Wired Connectors; 5000 mm

ENVIRONMENTAL/PHYSICAL CHARACTERISTICS

Light immunity	50000 lux
Status indicators	Leds on Emitter and Receiver Units
Operating temperature	0°C to 60°C
Material	Emitter & Receiver Sensor Units: Aluminum Extrusion
Size	31mm x 41mm

Operation

The AC Series are through scan safety light curtains. Emitter circuitry transmits modulated, infrared light that is detected by photo receiver circuitry. The number of light beams depends on the protected height and resolution of the safety light curtain.

Screen height

Screen height is the height from the top of the uppermost light beam to the bottom of the lowermost light beam.

Screen Height (mm)	No. of Channel	Pitch (mm)	Total Height (mm)	Resolution	Response time
145	8	18.3	205	30 mm	< 20ms
220	12		280		
290	16		350		
365	20		425		
440	24		500		
585	32		645		
660	36		720		
880	48		940		
290	8	36.6	350	60 mm	
440	12		500		
585	16		645		
730	20		790		
880	24		940		
1170	32		1230		
1315	36		1375		
1755	48		1815		

Resolution

AC Series safety light curtain resolution (sometimes called minimum object sensitivity) is the minimum object size that will always interrupt when it enters the sensing field. Anything entering the sensing field equal to or greater than this minimum size will be detected. Resolution is not affected by Sensing distance or dust accumulation. The AC Series does not require a sensitivity adjustment.

Two factors determine the resolution of the safety light curtain: beam center distance and light beam diameter. AC Series has a 30 mm resolution.

Mounting considerations

Optical alignment procedure

Proper optical alignment of the AC Series safety light curtains ensures optimum operation. Sensing units Emitter and Receiver must be parallel, at the same height and plane of the beams, and with an angular displacement.

For proper optical alignment. Perform alignment as follows:

Turn one of the sensing units around its longitudinal axis in both directions to locate the point where the sensing field is interrupted. Center the sensing unit between the two points of interruption for optimal adjustment.

After Alignment -

Emitter - **POWER ON - RED LED ON**
 READY - **YELLOW LED - ON**

Receiver - **POWER ON - RED LED ON**
 READY - **YELLOW LED - ON**
 OUTPUT - **GREEN LED - ON**
 WAIT - **RED LED - OFF**

Mounting

Option 1

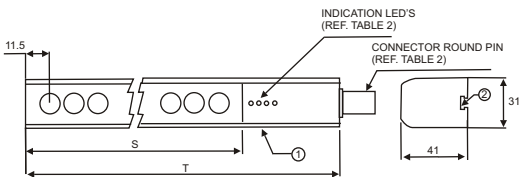
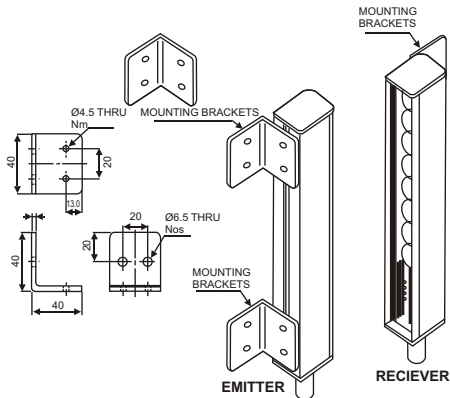

S = SCREEN HEIGHT (REF. TABLE 1)

T = TOTAL HEIGHT (REF. TABLE 1)

1. Extruded Aluminium section
2. T Slot for M4x6 Nuts

Option 2

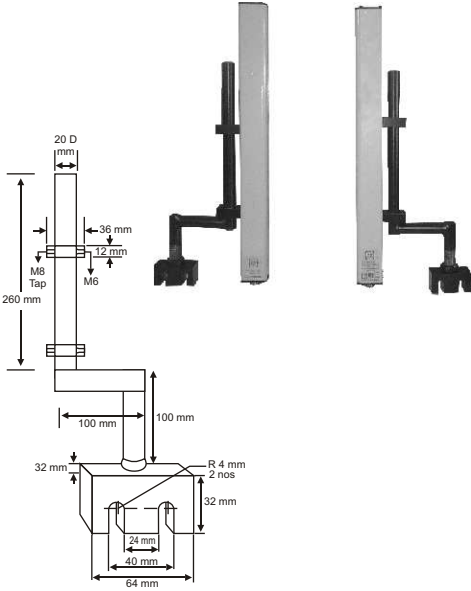

Option 3

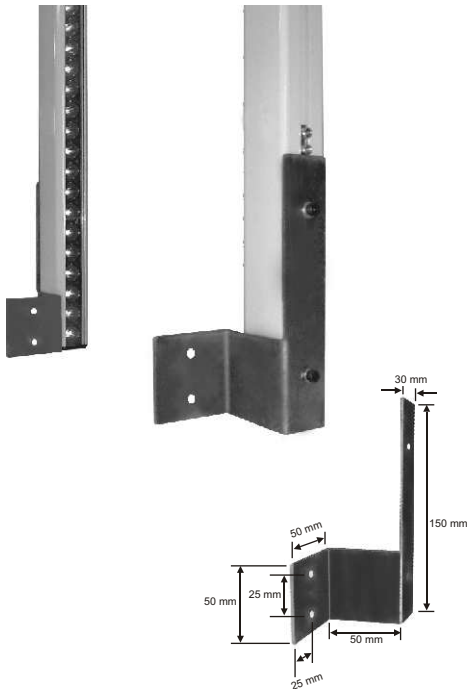

Pin Configuration

PIN NO.	EMITTER 2 PIN	RECEIVER 4 PIN
PIN1	BLACK - GND OV	BLACK - -GND OV
PIN2	RED - 24 VDC	RED - 24 VDC
PIN3	-----	YELLOW O/P1 - PNP NO
PIN4	-----	GREEN O/P2-PNP NO

O/P WIIRING DIAGRAM - PNP

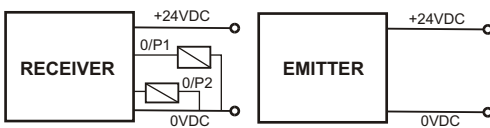

Diagram 1

O/P WIIRING DIAGRAM - NPN

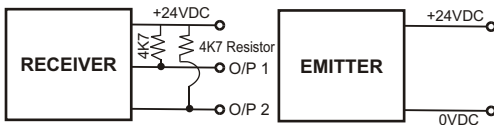

Diagram 2

Inspection and Maintenance

Inspection

Scheduled safety light curtain inspection

The following inspection must be carried out at power up daily and after any maintenance by a knowledgeable person designated by the machine user

- 1) On powering up, Safety light curtain performs **Self Check** test. During self check, status LED indications of Emitter and Receiver units show

Power - Red LED

Wait - Red LED.

- 2) After Self Check, Light Curtain starts normal operation if self check was successful.

During Normal operation, status LED indications are as shown,

Emitter unit – Power - Red LED

READY – Yellow LED

Receiver - POWER – RED LED

READY – Yellow LED

O/P – Green LED

- 3) Obstruct the sensing field. Check with the test rod- 30mm diameter

After Obstruction status LED indication are as shown,

Emitter - POWER – Red LED

READY – Yellow LED

Receiver - POWER – Red LED

READY – Yellow LED

O/P – Green LED will go OFF

Inserting the test rod into the sensing field plane must be done at three different locations: near each sensing unit and in the middle of the sensing field, Inserting the test rod into the sensing field during the machine operation must immediately stop the dangerous movement.

Inspection and test methods

Inspect	Test Method	Frequency
Object and machine Reaction	Insert a 30 mm rod in the light curtain sensing field and ensure the machine stops.	Daily, at each power up, and after each intervention (or maintenance) performed on the protective safety equipment
Operation of the machine control Circuitry	Test function generated by the machine / insert 30 mm test rod to obstruct Light Curtain	Each time the machine is used
Electrical wiring	Visually inspect the safety light curtain and the electrical wiring to ensure that they are in serviceable condition.	Based on environment and needs
Cleaning	Use a clean, soft, dry cloth for dust removal. Use a clean, soft cloth with soapy water for grease removal. Wipe without rubbing (rubbing causes streaks and static electricity that attracts dust). Products used to clean windows may be used. Never use solvents like petrol, white spirit, or acetone.	Based on environment and needs

Troubleshooting

Failure	Possible Cause	Inspect & Repair
1) Both Emitter & Receiver units show no Indication	1) No Power Supply 2) Power Supply Cable Damaged	1) Check/ replace Power supply 2) Replace with new Power Cable
2) Unit not going Proper Mode	1) Properly Aligned ? to Ready 2) Alignment surface close to the Emitter & receiver ?	1) Check 2) Any reflective Check / remove
3) All Status Indications are ON but no O/P available	1) Receiver Connector cable damaged 2) Attached load exceeds 100mA 3) Misalignment	1) Replace 2) Load should be less than 100mA
4) Output LED goes ON & OFF Continuously	1) Alignment Dust / Dirt on Acrylic 2) Machine not earthed	1) Check Proper Alignment Clean the dust by soft and dry cloth 2) Earthing should must be connected Properly
5) Emitter is On but Receiver is OFF OR Receiver is ON but Emitter is OFF	1) Emitter / Receiver power cable faulty	1) Replace

Applications

- 1) Power Presses
- 2) Hydraulic Presses
- 3) Press Brake
- 4) Injection Moulding Machines
- 5) Blow Moulding Machines
- 6) Robots
- 7) Hydro Pneumatic Presses
- 8) Special Purpose Machines
- 9) Elevators



Orbital Systems (Bombay) Pvt. Ltd.

F-129, Ansa Indl. Estate, Saki Vihar Road,
Mumbai - 400 072. India.

Tel.: 91-22-2847 3312 / 1274 / 6915

Fax : 91-22-2847 6675

E-mail: orbital@vsnl.net orbital@mtnl.net.in

Website: www.orbitalsystems.net